

Bissell®

Commercial

COMMERCIAL UPRIGHT EXTRACTOR

MODEL DC100

64P8 SERIES

- What's in the Box?3
- Product View.....3
- Assembly4
- Filling the Clean Water Tank.....5
- Using Your Machine.....6
- Cleaning with Attachments7
- Emptying the Dirty Water Tank8
- Cleaning the Hose & Tools.....8
- Maintaining the Brush Roll & Belt.....9
- Removing & Replacing the Brush Roll.....10
- Storing Your Machine10
- Troubleshooting.....11
- Warranty12
- Service12

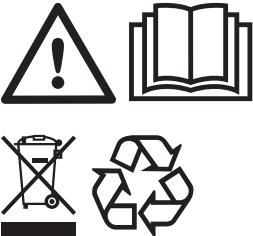
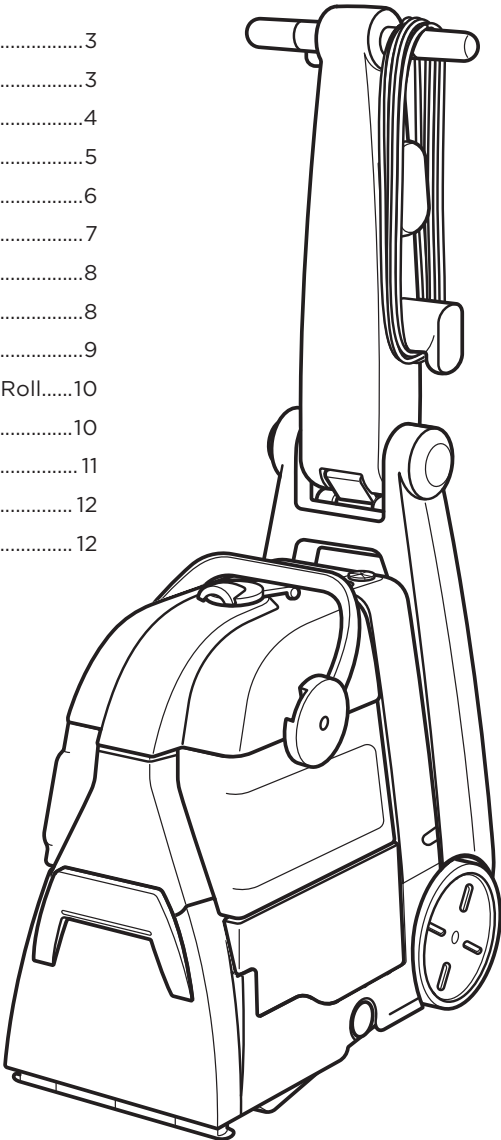

IMPORTANT SAFETY INSTRUCTIONS



READ ALL INSTRUCTIONS BEFORE USING YOUR APPLIANCE.

When using an electrical appliance, basic precautions should be observed, including the following:



WARNING

TO REDUCE THE RISK OF FIRE, ELECTRIC SHOCK OR INJURY:

- » Do not immerse.
- » Use only on surfaces moistened by cleaning process.
- » Always connect to a properly grounded outlet.
- » See grounding instructions.
- » Unplug from outlet when not in use and before conducting maintenance or troubleshooting.
- » Do not leave machine when it is plugged in.
- » Do not service machine when it is plugged in.
- » Do not use with damaged cord or plug.
- » If appliance is not working as it should, has been dropped, damaged, left outdoors, or dropped into water, have it repaired at an authorized service center.
- » Use indoors only.
- » Do not pull or carry by cord, use cord as a handle, close door on cord, pull cord around sharp corners or edges, run appliance over cord, or expose cord to heated surfaces.
- » Unplug by grasping the plug, not the cord.
- » Do not handle plug or appliance with wet hands.
- » Do not put any object into appliance openings, use with blocked opening or restrict air flow.
- » Do not expose hair, loose clothing, fingers, or other body parts to openings or moving parts.
- » Do not pick up hot or burning objects.
- » Do not pick up flammable or combustible materials (lighter fluid, gasoline, kerosene, etc.) or use in the presence of explosive liquids or vapor.
- » Do not use appliance in an enclosed space filled with vapors given off by oil-based paint, paint thinner, some mothproofing substances, flammable dust, or other explosive or toxic vapors.
- » Do not pick up toxic material (chlorine bleach, ammonia, drain cleaner, gasoline, etc.).
- » Do not modify the 3-prong grounded plug.
- » Do not allow to be used as a toy.
- » Do not use for any purpose other than described in this user guide.
- » Do not unplug by pulling on the cord.
- » Use only manufacturer's recommended attachments.
- » Always install float before any wet pick-up operation.
- » Use only cleaning products formulated by BISSELL® Commercial for use in this appliance to prevent internal component damage. See the cleaning fluid section of this guide.
- » Keep openings free of dust, lint, hair, etc.
- » Do not point attachment nozzle at people or animals
- » Keep appliance on a level surface.
- » Do not use without intake screen filter in place.
- » Turn OFF all controls before unplugging.
- » Unplug before attaching the Upholstery Tool.
- » Be extra careful when cleaning stairs.
- » Close attention is necessary when used by or near children.
- » If your appliance is fitted with a nonwireable BS 1363 plug it must not be used unless a 13 amp (ASTA approved to BS 1362) fuse is fitted in the carrier contained in the plug. Spares may be obtained from your BISSELL supplier. If for any reason the plug is cut off, it must be disposed of, as it is an electric shock hazard should it be inserted into a 13 amp socket.

SAVE THESE INSTRUCTIONS

THIS MODEL IS FOR COMMERCIAL USE.

⚠️ WARNING

Improper connection of the equipment-grounding conductor can result in a risk of electrical shock. Check with a qualified electrician or service person if you aren't sure if the outlet is properly grounded. **DO NOT MODIFY THE PLUG.** If it will not fit the outlet, have a proper outlet installed by a qualified electrician. This appliance is designed for use on a nominal 120-volt circuit, and has a grounding attachment plug that looks like the plug in the illustration. Make certain that the appliance is connected to an outlet having the same configuration as the plug. No plug adapter should be used with this appliance.

GROUNDING INSTRUCTIONS

This appliance must be connected to a grounded wiring system. If it should malfunction or break down, grounding provides a safe path of least resistance for electrical current, reducing the risk of electrical shock. The cord for this appliance has an equipment-grounding conductor and a grounding plug. It must only be plugged into an outlet that is properly installed and grounded in accordance with all local codes and ordinances.

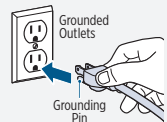

What's in the Box?

Standard accessories may vary by model. To identify what should be included with your purchase, please refer to the "Carton Contents" list located on the carton top flap.

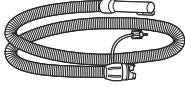
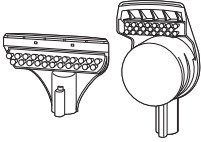
		
Fully Assembled Machine	Hose	Tools (vary by model)

Product View

1. Spray Trigger
2. Adjustable Handle
3. Tank Carry Handle
4. Hose Latch/Connection
5. Flow Indicator
6. Cleaning Solution Connection
7. Dirty Water Tank
8. Front Carry Handle
9. Clean Water Tank
10. Power Switch
11. Upper Handle Release
12. Back Carry Handle
13. Recline Handle

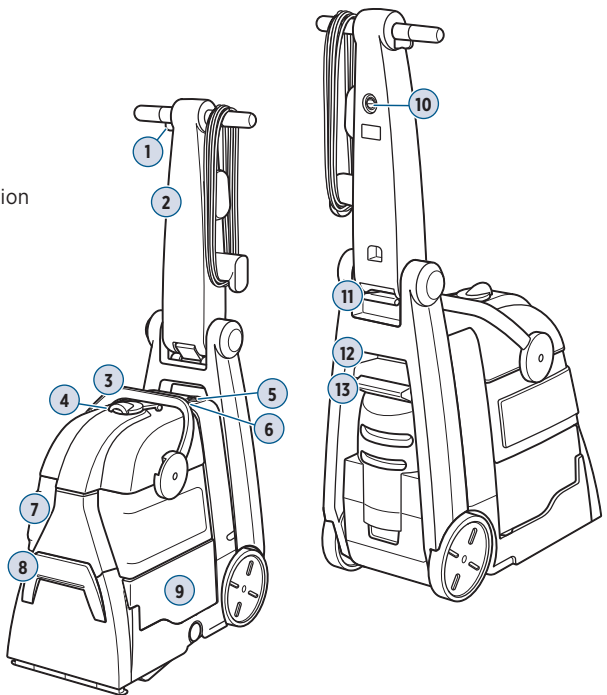

Assembly

Your machine comes fully assembled. Before first use, ensure tanks are firmly in place and any inserts are removed from the dirty water tank.

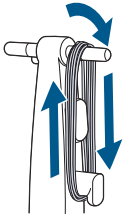

1. Wrap cord around holder.

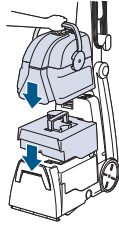

2. Slide clean and dirty water tanks into place.

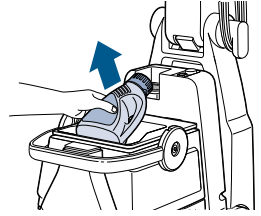

3. Remove any inserts from the dirty water tank.

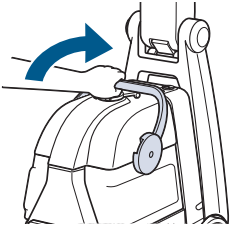

4. Push the dirty water tank handle back until it locks in place with a click.

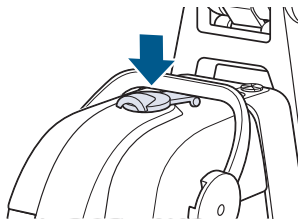

5. Ensure hose latch is closed completely to avoid suction issues.

Filling the Clean Water Tank

View our full lineup of powerful carpet cleaning formulas at BISSELL-commercial.co.uk.



Always use genuine BISSELL® Commercial formulas in your machine. Other formulas may harm the machine.

Pretreat

Pretreat spots and stains to improve carpet cleaning performance.



Ultimate Stain Destroyer
30-second stain removal.

Carpet Cleaning Formula

Keep plenty of BISSELL Commercial formulas on hand so you can clean whenever it fits your schedule.

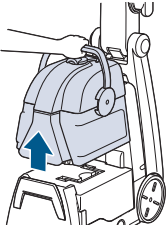
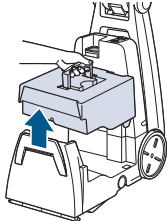
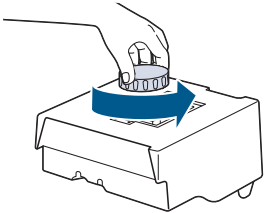
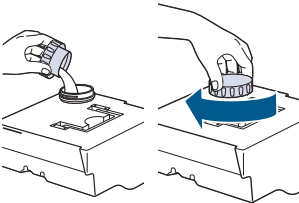
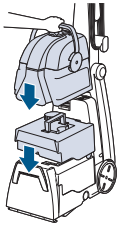
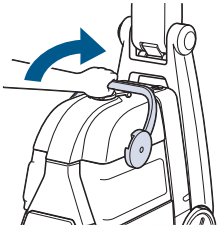

Ultimate + OXY
Removes deep down dirt, stains, & odours

		
<p>1. To remove the dirty water tank, lift the tank handle straight up.</p>	<p>2. Lift clean water tank from the base of machine.</p>	<p>3. Remove cap and fill clean water tank to the FILL line with hot water. Do not boil or microwave water.</p>
		
<p>4. Use tank cap to measure formula. Use two capfuls of formula for a full tank.</p>	<p>5. Replace the clean and dirty water tanks.</p>	<p>6. Push the dirty water tank handle back until it locks into place with a click.</p>

! WARNING To reduce the risk of fire and electric shock due to internal component damage, use only BISSELL Commercial cleaning formula intended for use with this machine.

Using Your Machine

➤ To purchase additional tools or formulas, visit BISSELL-commercial.co.uk.



Carpet Cleaning Tips

- Move furniture to another area if cleaning the entire room (optional).
- Vacuum area with a dry vacuum cleaner thoroughly before deep cleaning.
- Plan your cleaning route to leave an exit path. It is best to begin in the corner farthest from your exit.
- Pretreating is recommended to improve cleaning for heavily soiled carpet in high-traffic areas.
- Your machine has a circuit breaker that automatically shuts off the brush if a large or loose object gets caught in it. If that happens, unplug your machine, remove the object and plug machine in to reset the circuit breaker.
- You may notice hair and debris deposits on the carpet or in the tank that were loosened while cleaning (especially with newer carpets that have never been deep cleaned before). This debris should be picked up and thrown away.

<p>1. Plug into a proper outlet.</p>	<p>2. Turn the power switch to the ON position.</p>	<p>3. Recline handle by pushing the green lever on the back of the machine down while pulling the handle back.</p>

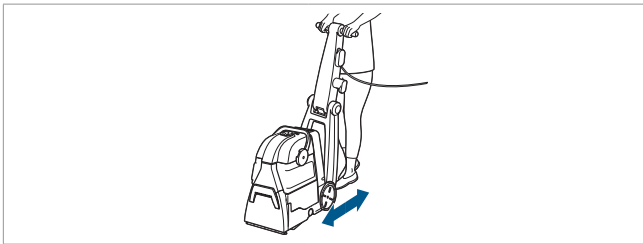

4. Make cleaning passes until solution being pulled up appears clean. For best results, overlap passes to avoid streaks in your carpet.

Step One: Hold Spray Trigger

- 1 pass forward
- 1 pass back

Step Two: Release Spray Trigger

- 1 pass forward
- 1 pass back

⚠ WARNING To reduce the risk of injury, use extra care when cleaning on stairs. Keep machine on a level surface.

NOTICE Do not overwet. Take care not to run over loose objects or edges of area rugs. Stalling brush may result in premature belt failure. Some Berber carpets have a tendency to fuzz with wear. Repeated strokes in the same area with an ordinary vacuum or deep cleaner may aggravate this condition.



Upholstery Cleaning Tips

- Check manufacturer's tag before cleaning. "W" or "WS" on the tag means you can use your deep cleaning machine. If the tag is coded with an "X" or an "S" (with a diagonal stripe through it) or says "Dry Clean Only", do not proceed with any deep cleaning machine. Do not use on velvet or silk. If manufacturer's tag is missing or not coded, check with your furniture dealer.
- Check for colorfastness in an inconspicuous place.
- If possible, check upholstery stuffing. Colored stuffing may bleed through fabric when wet.
- Vacuum thoroughly to pick up loose debris and pet hair. Use a vacuum with a brush attachment and a crevice tool to clean in fabric folds.

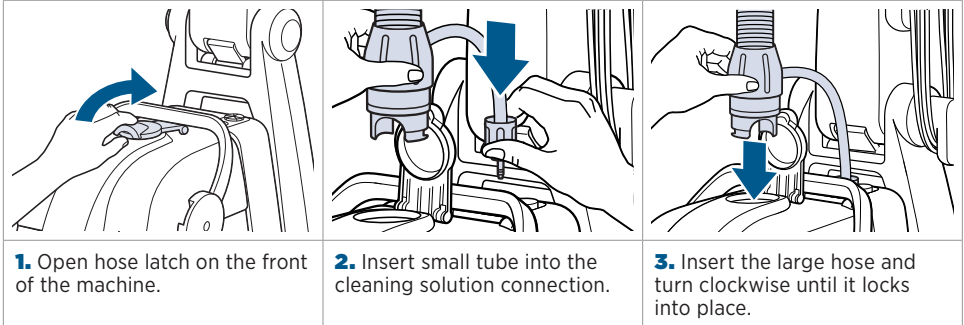

1. Open hose latch on the front of the machine.

2. Insert small tube into the cleaning solution connection.

3. Insert the large hose and turn clockwise until it locks into place.

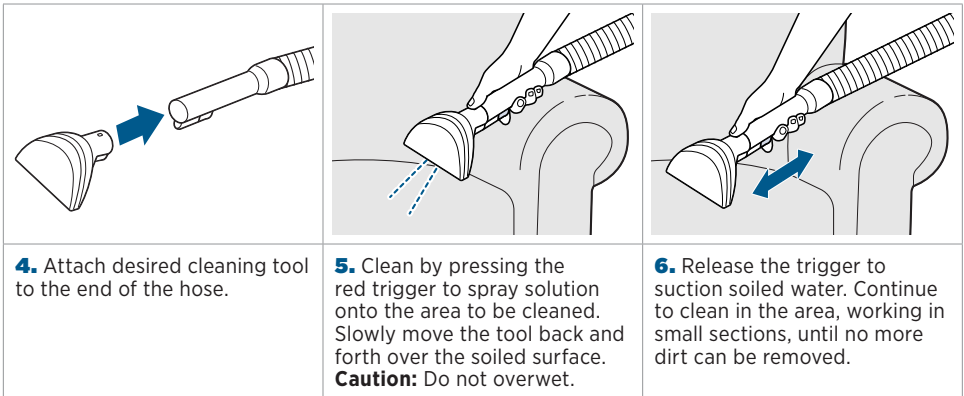

4. Attach desired cleaning tool to the end of the hose.

5. Clean by pressing the red trigger to spray solution onto the area to be cleaned. Slowly move the tool back and forth over the soiled surface.
Caution: Do not overwet.

6. Release the trigger to suction soiled water. Continue to clean in the area, working in small sections, until no more dirt can be removed.

⚠ WARNING To reduce the risk of injury, use extra care when cleaning on stairs. Keep machine on a level surface.

Emptying the Dirty Water Tank

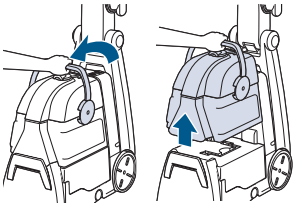

1. To remove the dirty water tank, lift the tank handle straight up. Carry the tank like a bucket to a utility sink or outside where you will dispose of the dirty water.

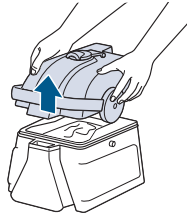

2. Unlatch the top of the tank from the bottom by pushing the handle all the way forward and lifting the top off. Pour dirty water into the sink.

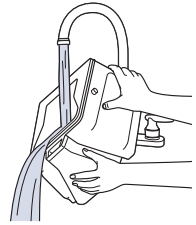

3. Rinse both parts of the dirty water tank with warm tap water. The top half of the tank can be rinsed clean through the nozzle area.

Cleaning the Hose & Tools

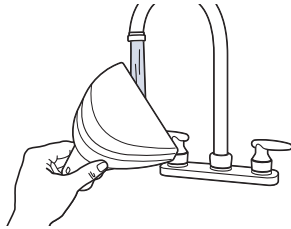

1. Remove attachments from the hose and rinse them clean under running water. Set them aside to dry.

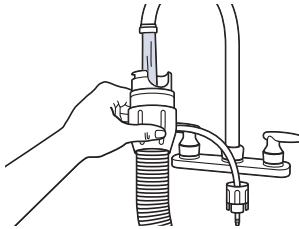

2. Remove the hose from the machine and run tap water through both ends.

⚠️ WARNING To reduce the risk of electric shock, turn power switch OFF and disconnect plug from electrical outlet before performing maintenance or troubleshooting checks.

Maintaining the Brush Roll & Belt

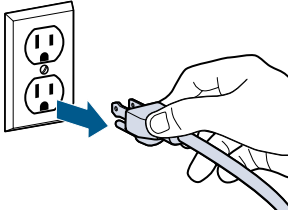

1. Turn OFF the machine and unplug it from the outlet.

Remove the dirty and clean water tanks from the machine.

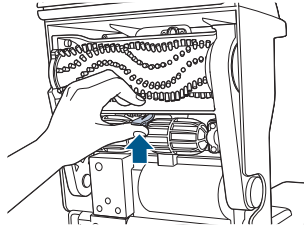

2. While standing behind the machine, lay it on its side.

Looking at the bottom of machine, find the carriage latch in the back center of the brush carriage. It's between the brush assembly and the front wheels.

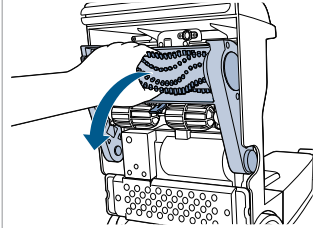

3. Pull brush carriage out, towards you, with one hand and pinch the latch with your other. The carriage should swing out to access belt cover.

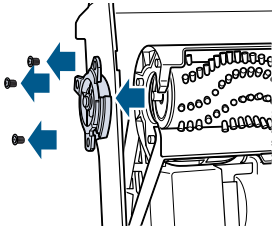

4. Remove three screws from cover.

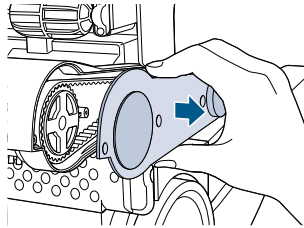

5. Lift and remove to access brush carriage.

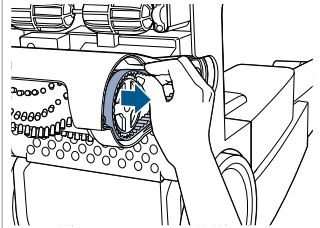

6. Turn the belt inward towards the large pulley while lifting out.

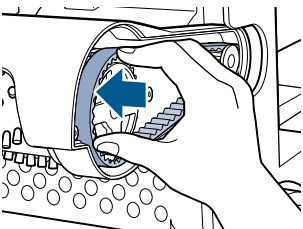

7. Place new belt over small pulley first and then slip the belt over the large pulley.

Note: Test the brush roll to make sure it spins freely before moving to the next step.

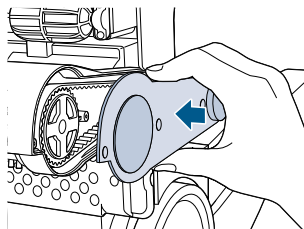

8. Replace the brush carriage and screws.

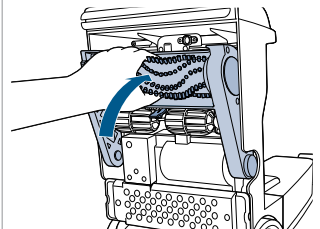

9. Push brush carriage back into place making sure the carriage latch locks back into place.

⚠️ WARNING To reduce the risk of electric shock, turn power switch OFF and disconnect plug from electrical outlet before performing maintenance or troubleshooting checks.

Removing & Replacing the Brush Roll

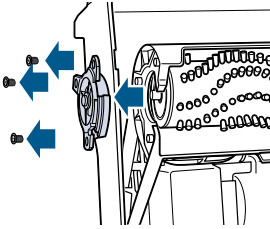

1. Remove three screws from endcap. Pull endcap off to release brush roll. The brush comes out easily by tilting the loose end out of the carriage.

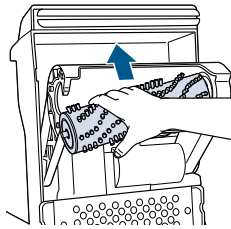

2. To replace the brush roll, put the large open end of the brush onto the carriage and tilt the opposite end back into place. Use a cloth to wipe debris from brush roll chamber.

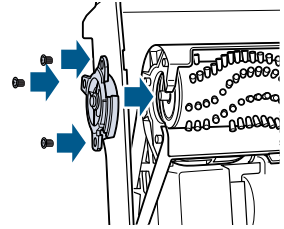

3. With the brush sitting relatively straight up and down by itself, place endcap back on top and replace three screws. Hold the brush center to the cover while placing it back on.

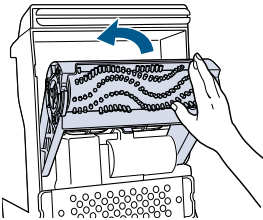

4. Spin the brush by hand to make sure it turns freely with some minor resistance from the motor. Push brush carriage back into place.

Storing Your Machine

Once your cleaning is complete, make sure both the dirty and clean water tanks are emptied, rinsed and dried before the next use. Store cleaner in a protected, dry area.

NOTICE To reduce the risk of a leaking condition, do not store machine where freezing may occur. Damage to internal components may result.

⚠ WARNING To reduce the risk of electric shock, turn power switch OFF and disconnect plug from electrical outlet before performing maintenance or troubleshooting checks.

Troubleshooting

Below are some of the issues you may run into. If you don't see the issue you're experiencing below, visit BISSELL-commercial.co.uk.



Problem	Possible Cause	Remedies
Reduced or no spray	Clean water tank may be empty.	Fill tank with hot tap water.
	Tank may not be seated completely.	Turn power OFF. Remove and reseal tank.
	Pump may have lost prime.	Turn power OFF and then back ON. Wait one minute, then press trigger.
	Debris filter on base is clogged.	Turn power OFF. Use hand to remove debris.
DirtLifter® PowerBrush does not turn	The belt is off or broken.	Turn power OFF and unplug machine from outlet. Follow instructions on page 9.
	The machine is in the upright position.	Brushes only rotate when machine is reclined using the recline handle.
	Circuit breaker on machine may have tripped.	Turn the machine OFF and unplug from outlet. Check to see if foreign object is caught in brush roll. Remove object. Plug machine in to reset circuit breaker.
Cleaner not picking up solution	Tanks may not be seated properly.	Turn the machine OFF. Pick up both the clean and dirty water tanks and reseal them so they fit snugly on the machine.
	Hose cap may not be snapped into place.	Turn the machine OFF. Ensure hose cap is placed on machine tightly and will not come off.
	Clean water tank is empty.	Check fluid levels in clean water tank and refill if necessary.
	Dirty water tank has picked up the maximum amount.	Empty dirty water tank.
	Red float "door" in the tank may have closed as a result of bumping an object or moving machine back and forth too quickly.	Turn the machine OFF, allowing red float door to release into the open position. Turn the machine back ON to continue cleaning. Be sure your forward and backward strokes are completed at a slower pace.
	Front nozzle of machine is clogged.	Turn the machine OFF. Use fingers to remove any debris from this area.
	Upper body filter is clogged.	Turn the machine OFF. Use fingers to remove any debris from this area.

⚠️ WARNING To reduce the risk of electric shock, turn power OFF and disconnect plug from electrical outlet before performing maintenance or troubleshooting checks.

Warranty

This warranty gives you specific legal rights, and you may also have other rights which may vary from country to country. If you need additional instruction regarding this warranty or have questions regarding what it may cover, please contact BISSELL® Commercial Consumer Care by e-mail or telephone as described below.

Limited One-Year Commercial Warranty

Subject to the *EXCEPTIONS AND EXCLUSIONS identified below, upon receipt of the product BISSELL Commercial will repair or replace (with new, refurbished, lightly used, or remanufactured components or products), at BISSELL Commercial's option, free of charge from the date of purchase by the original purchaser, for one year, any defective or malfunctioning part. See information below. This warranty does not apply to fans or routine maintenance components such as filters, belts, or brushes. Damage or malfunction caused by negligence, abuse, neglect, unauthorized repair, or any other use not in accordance with the user guide is not covered.

BISSELL Commercial is not liable for incidental or consequential damages of any nature associated with the use of this product. BISSELL Commercial's liability will not exceed the purchase price of the product. Some countries do not allow the exclusion or limitation of incidental or consequential damages, so the above limitation or exclusion may not apply to you.

*Exceptions and Exclusions From the Terms of the Limited Warranty

This warranty is exclusive and in lieu of any other warranties, either oral or written. Any implied warranties which may arise by operation of law, including the implied warranties of merchantability and fitness for a particular purpose, are limited to the one-year duration from the date of purchase as described above. Some countries do not allow limitations on how long an implied warranty lasts so the above limitation may not apply to you.

Note: Please keep your original sales receipt. It provides proof of date of purchase in the event of a warranty claim.

Service

If your BISSELL Commercial product should require a service, for information about repairs and replacement parts, or for questions about your warranty, please contact the distributor where the product was purchased.

If your query remains unresolved, please visit BISSELL-commercial.co.uk.



©2022 BISSELL Inc. All rights reserved.

BISSELL International Trading Company BV, Postbus 12874, 1100 AW Amsterdam Zuidoost, The Netherlands
BISSELL product imported into UK by: Beam Group, Unit 400, Buckingham Business Park, Swavesey CB24 4UQ
Part Number 1633077 05/22 RevA